

DETAIL OF DFX-830*2F

WATER LINE D60
AIR LINE D42

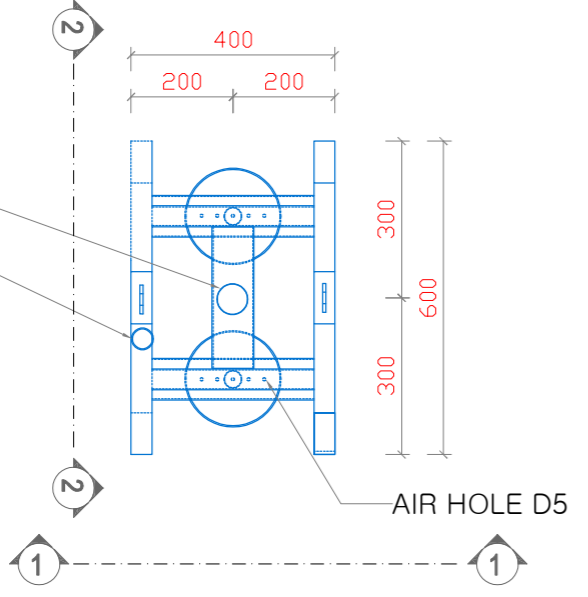

FLOOR PLAN

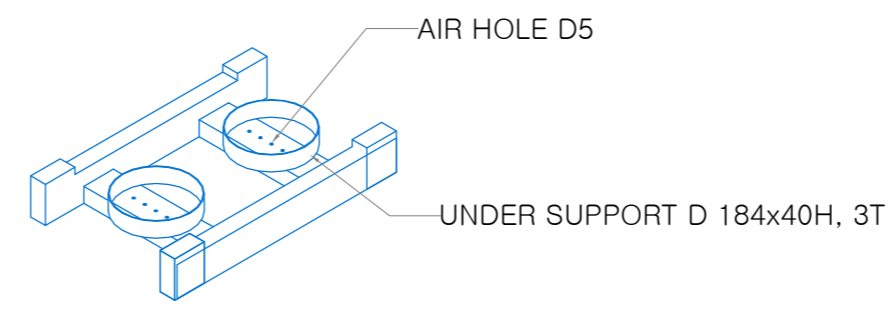

AIR HOLE DETAIL

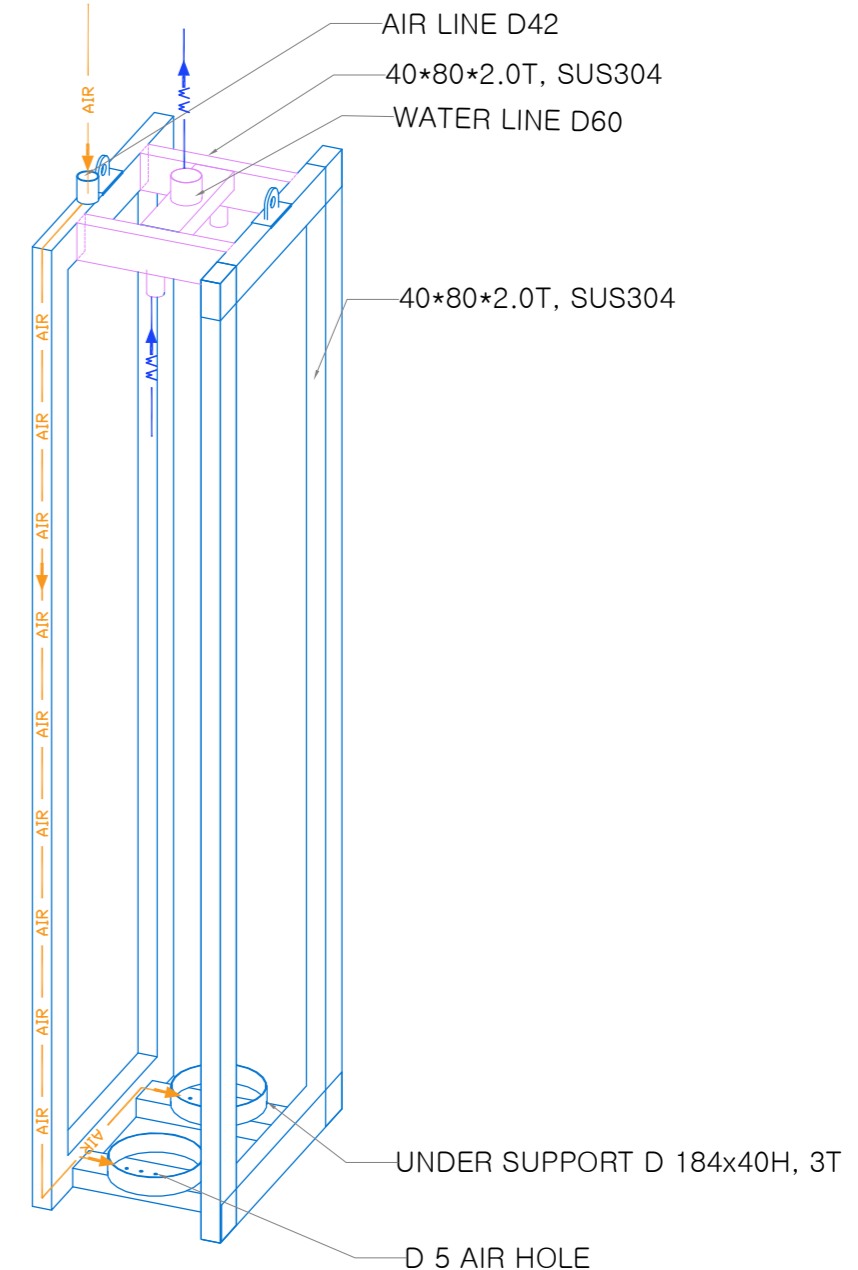

ISOMETRIC

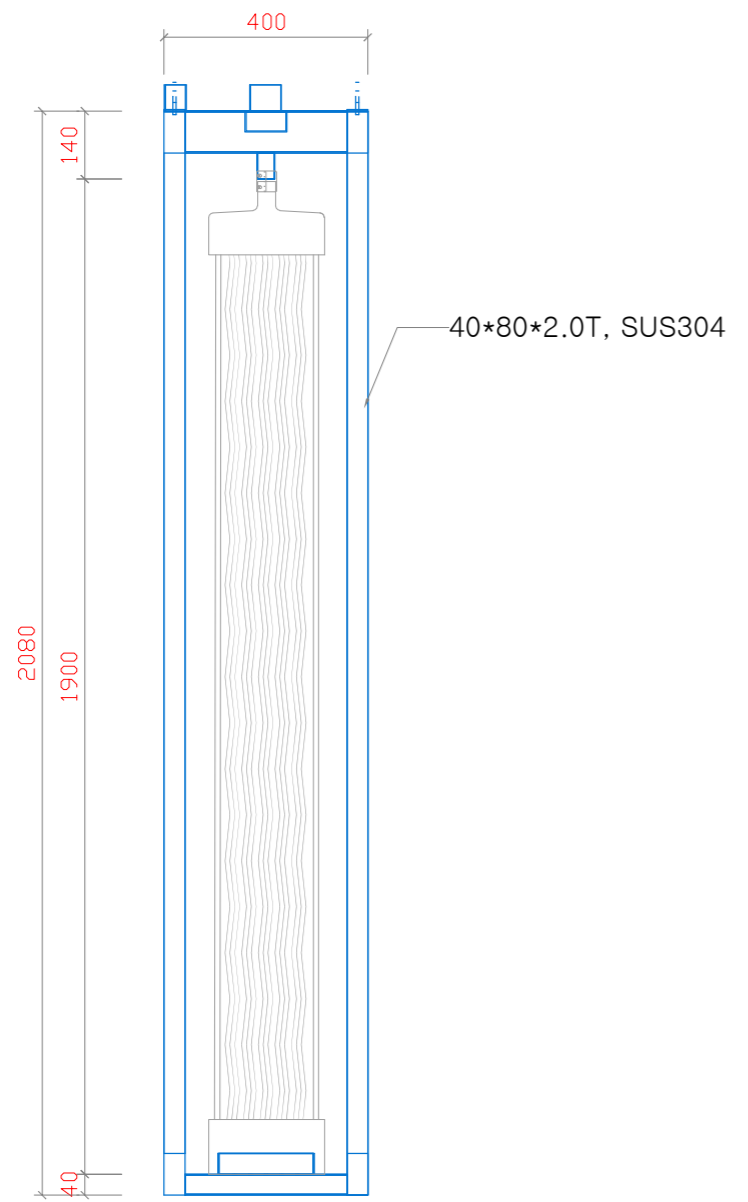

SECTION 1-1



SECTION 2-2

REV.	DATE	DESCRIPTION	DWN	CKD	RVD	PM

PROJECT NAME	
CLIENT	
DEERFOS MEMBRANES	
TITLE	DETAIL OF DFX-830 * 2F
SCALE	N/S
REV.	



DETAIL OF DFX-830*4F

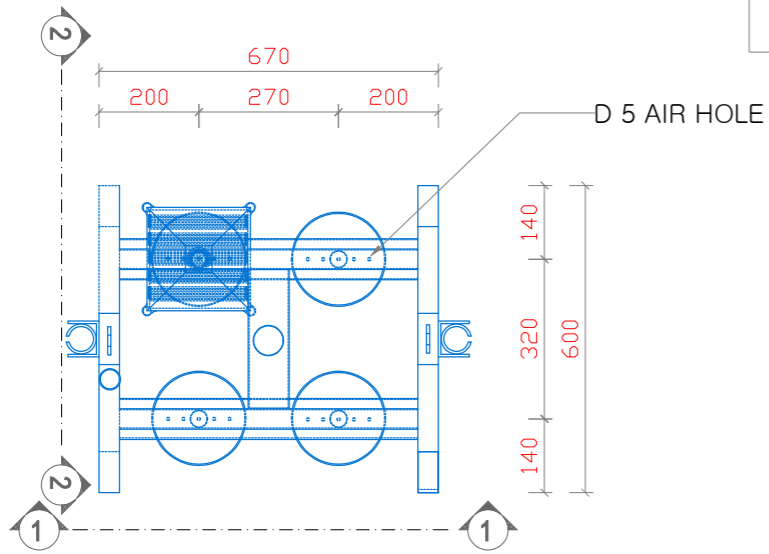

FLOOR PLAN

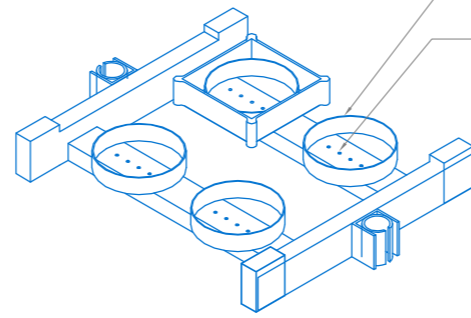

AIR HOLE DETAIL

UNDER SUPPORT D 184x40H, 3T
AIR HOLE D5

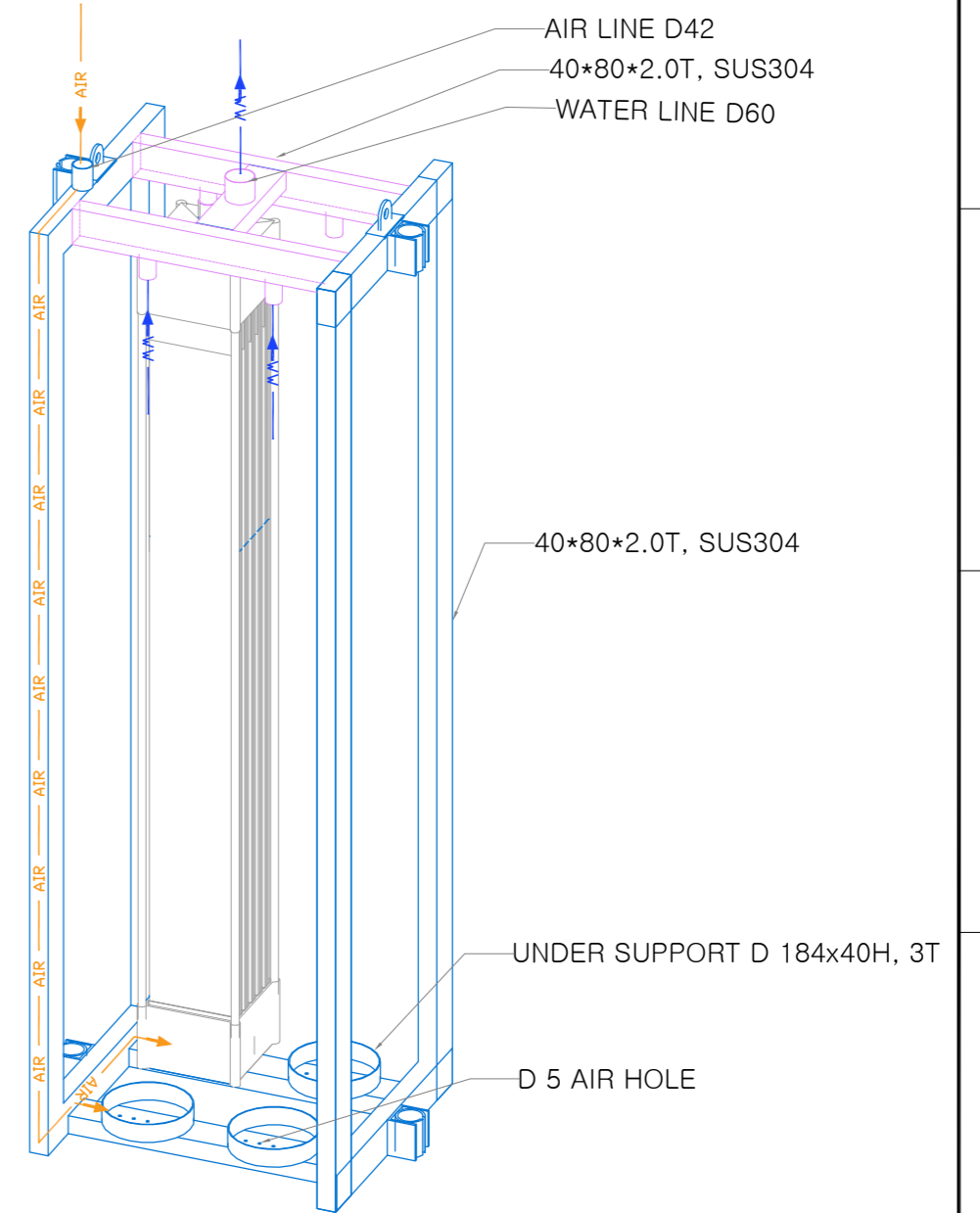

ISOMETRIC

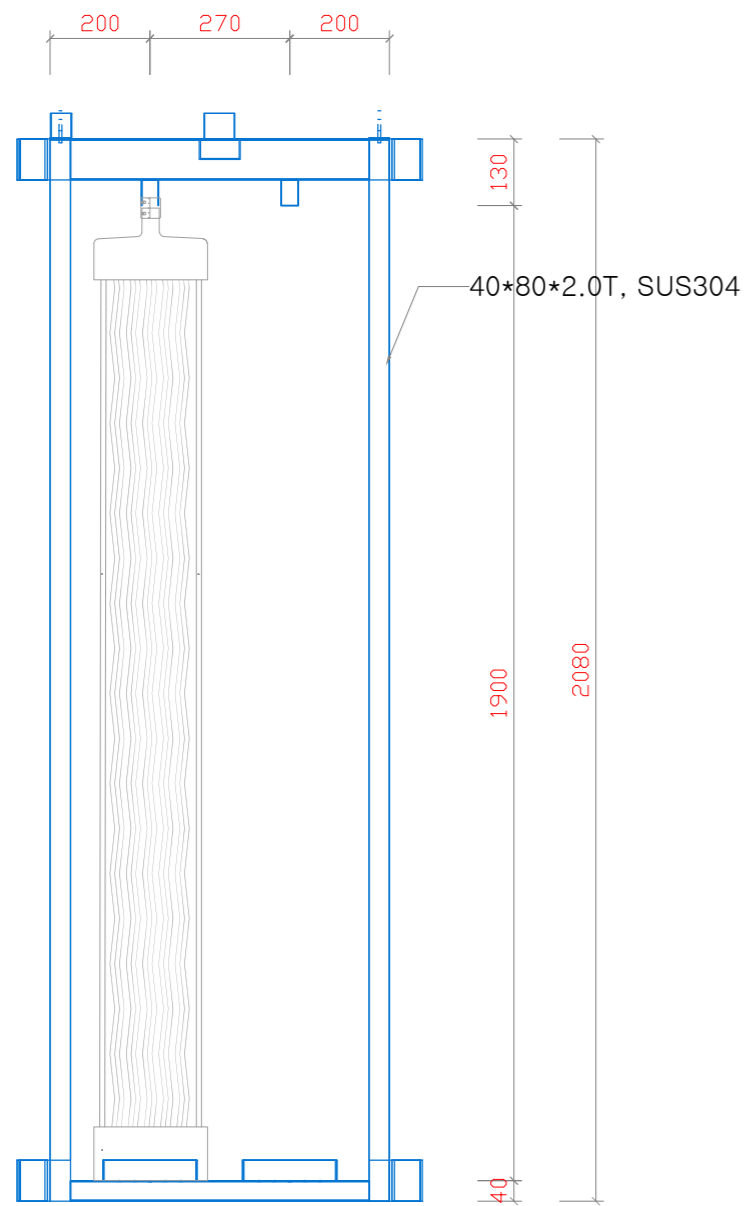

SECTION 1-1

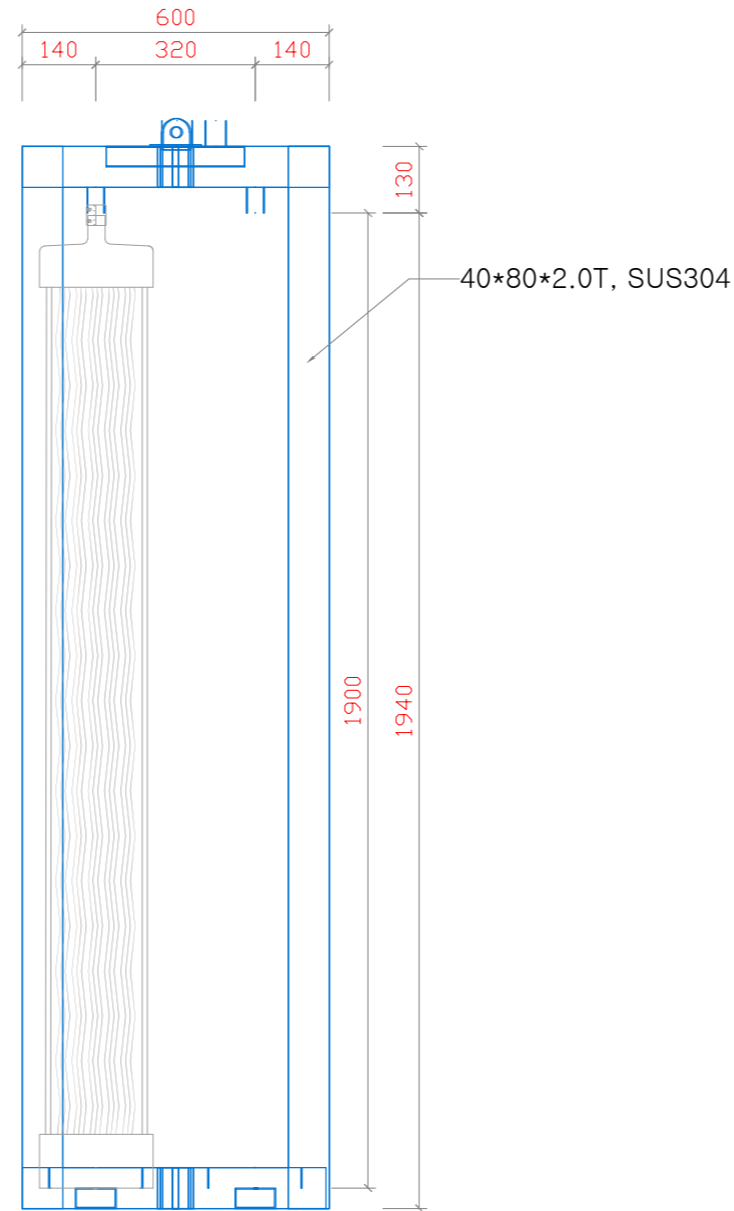

SECTION 2-2

REV.	DATE	DESCRIPTION	DWN	CKD	RVD	PM

PROJECT NAME	
CLIENT	
DEERFOS MEMBRANES	
TITLE	DETAIL OF DFX-830 * 4F
SCALE	N/S
REV.	



DETAIL OF DFX-830*6F

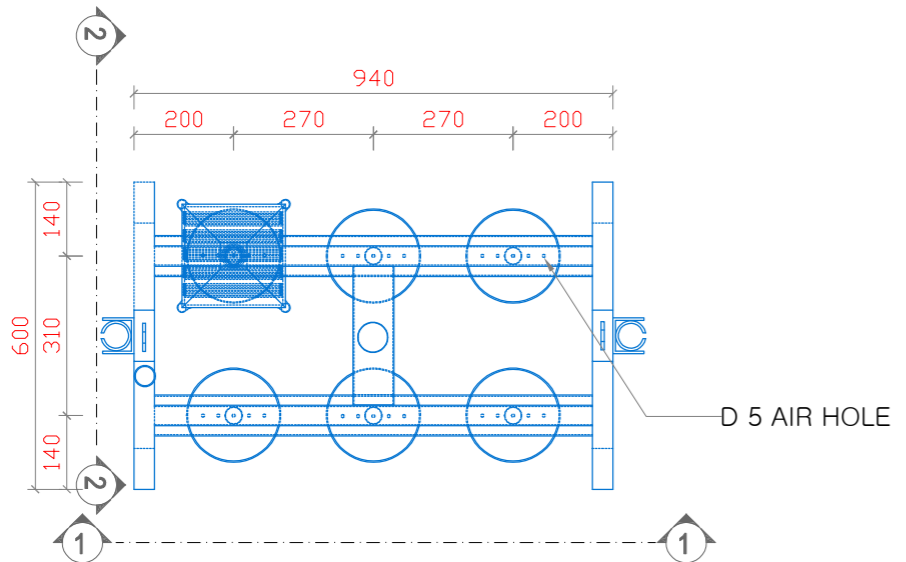

FLOOR PLAN

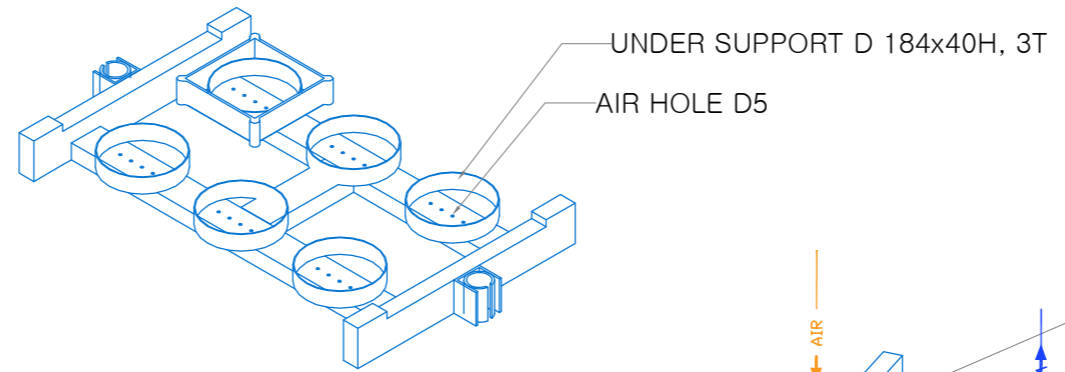

AIR HOLE DETAIL

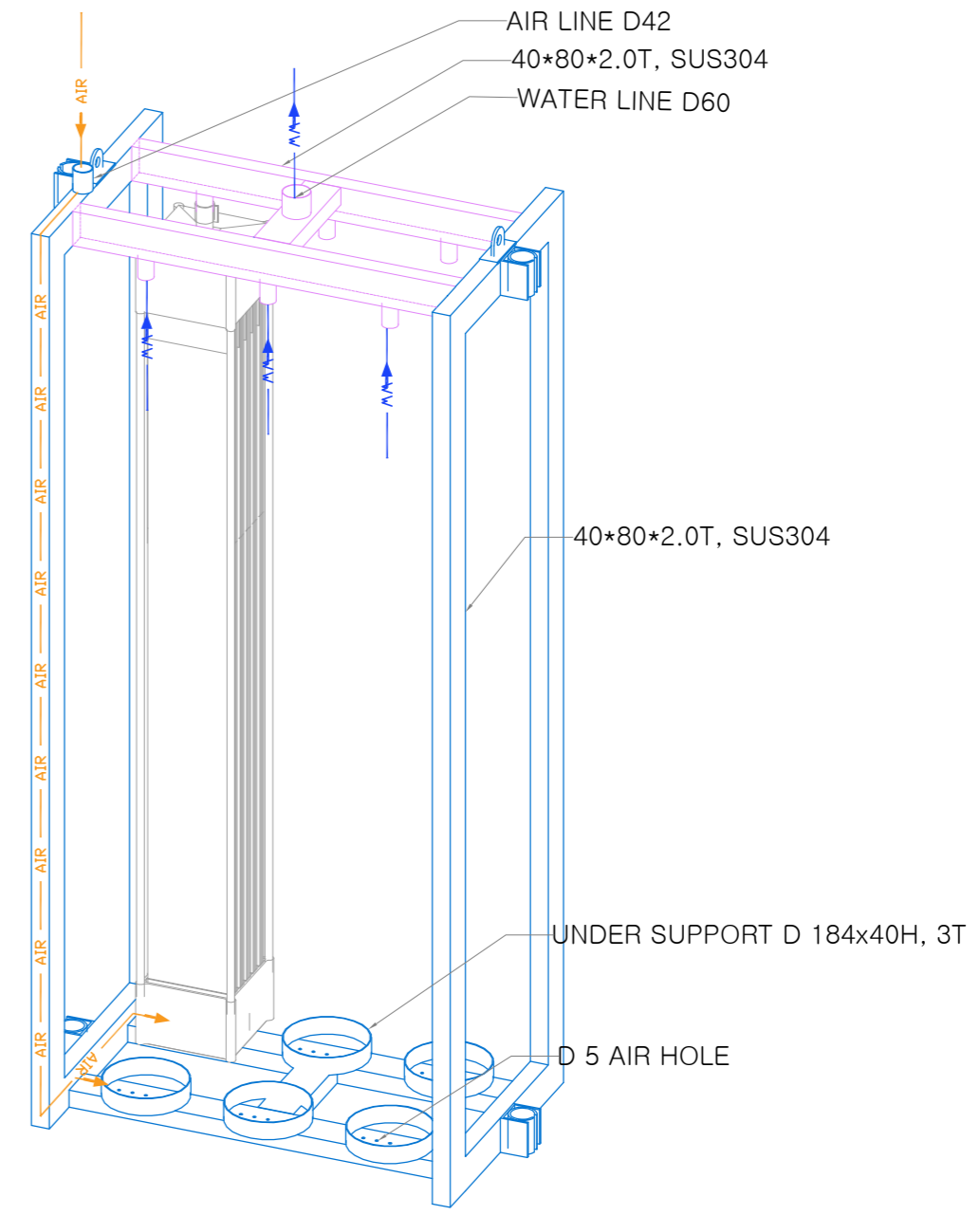

ISOMETRIC

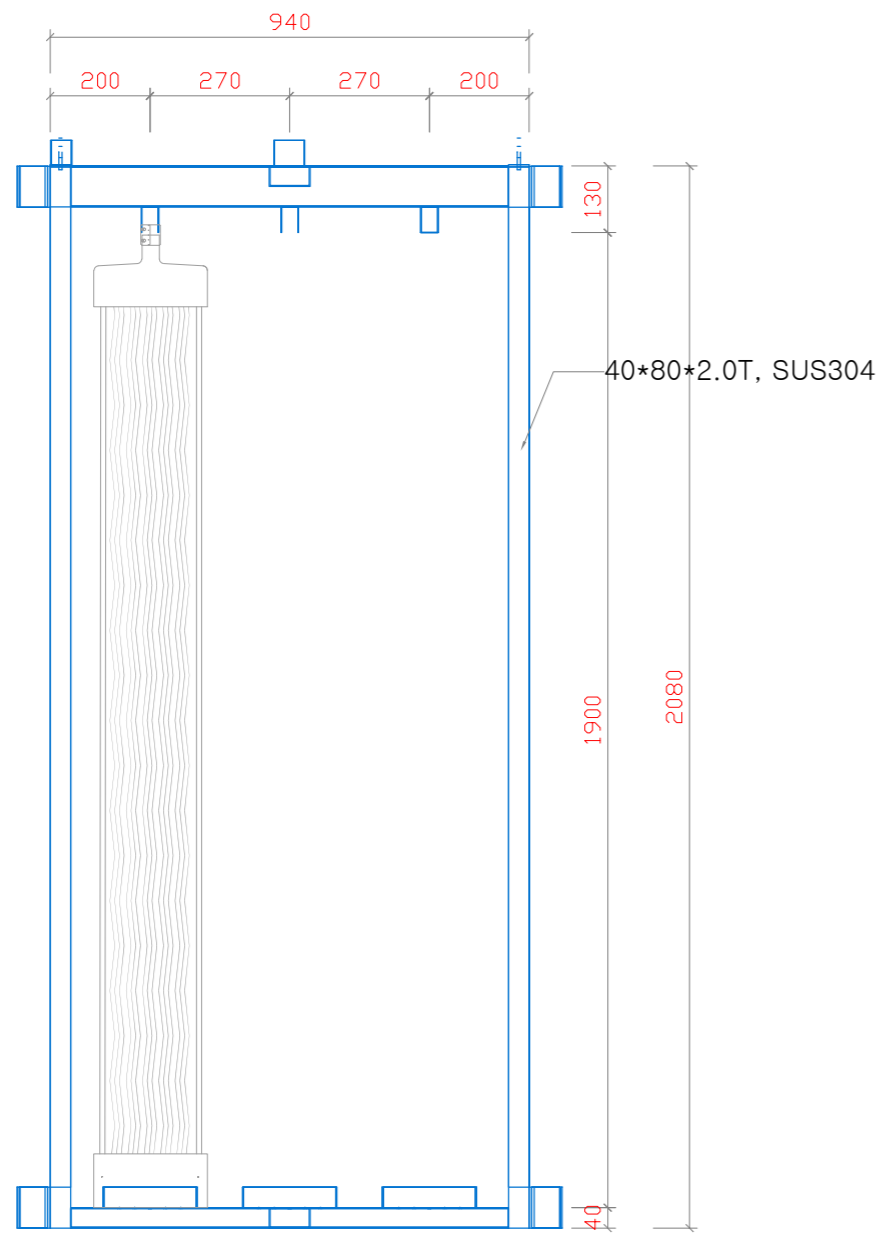

SECTION 1-1

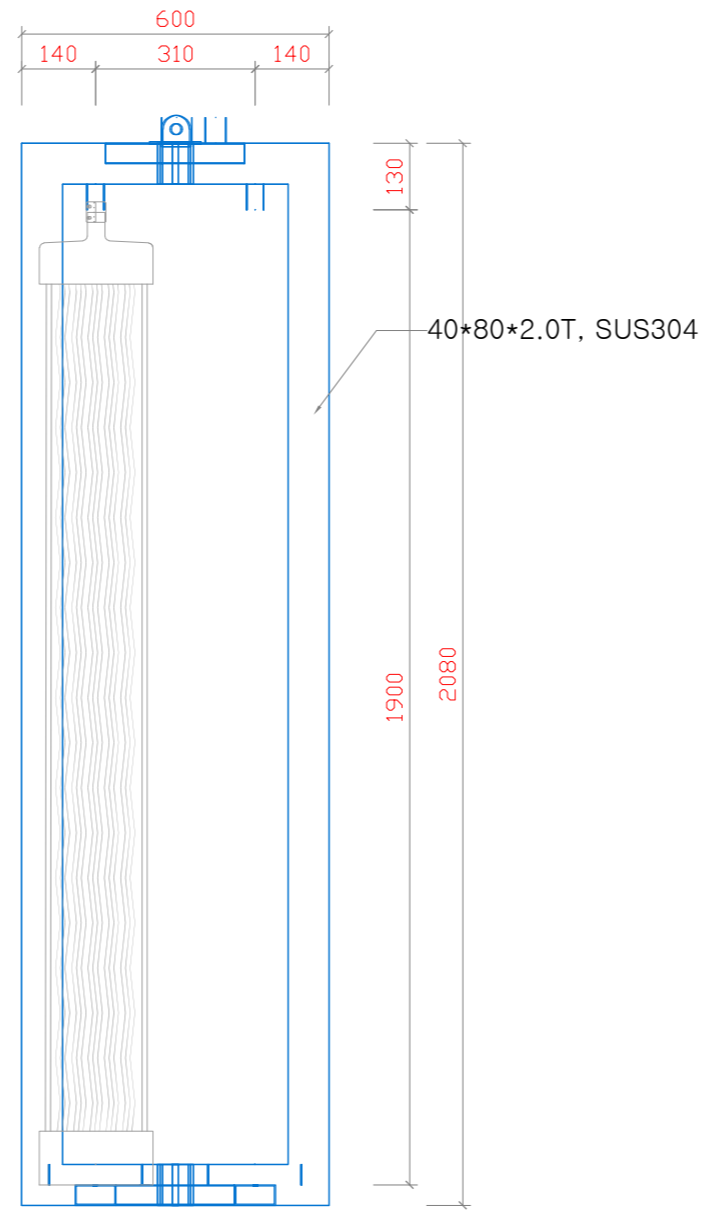

SECTION 2-2

REV.	DATE	DESCRIPTION	DWN	CKD	RVD	PM

PROJECT NAME	
CLIENT	
DEERFOS MEMBRANES	
TITLE	DETAIL OF DFX-830 * 6F
SCALE	N/S
REV.	



DETAIL OF DFX-830*8F

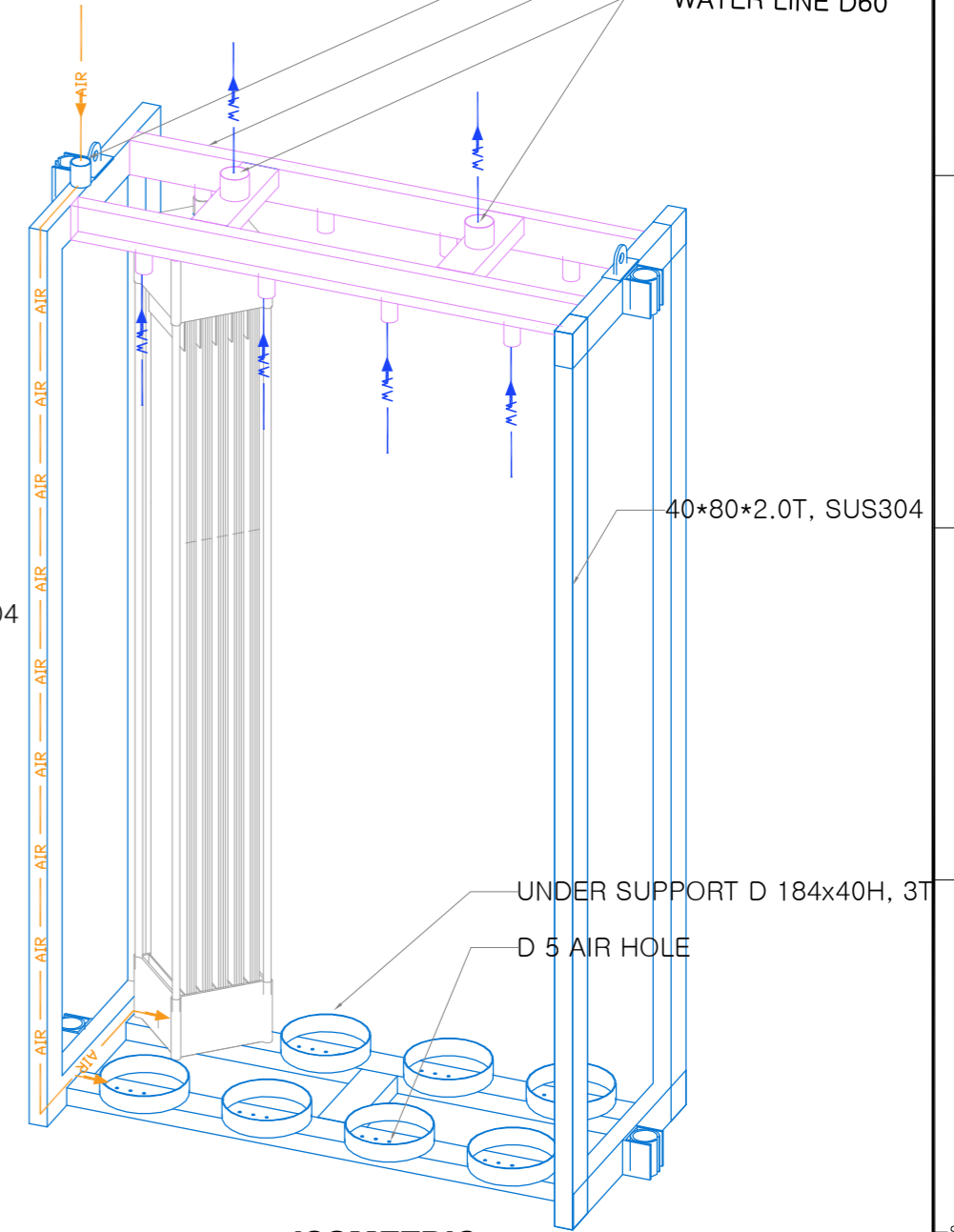
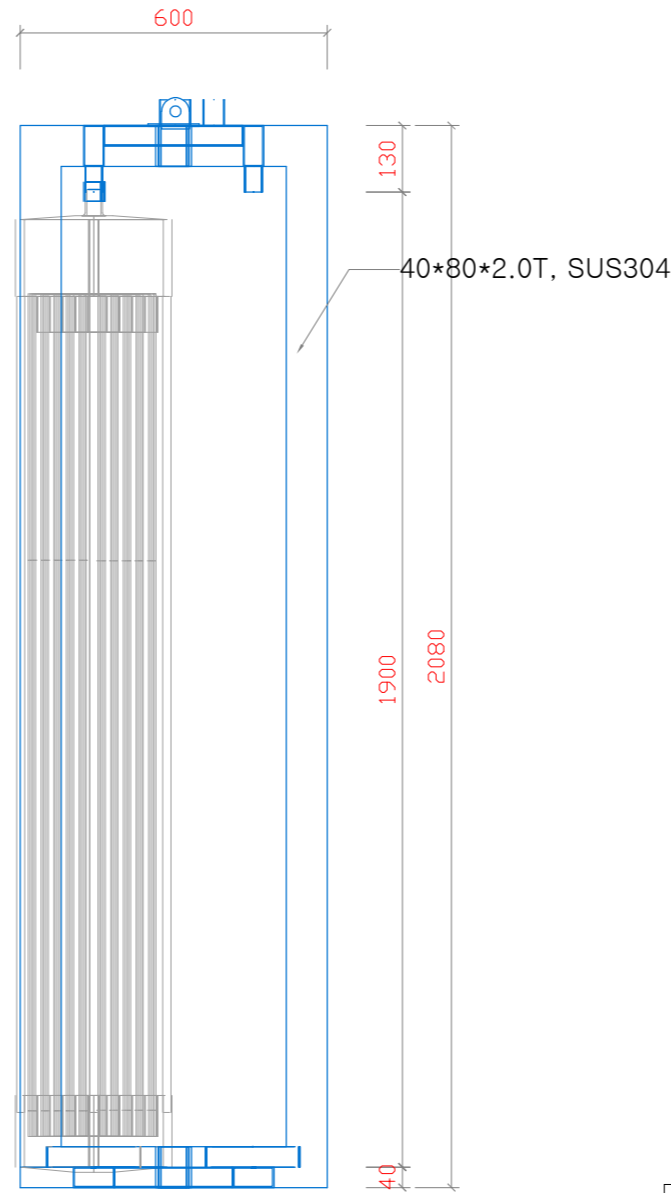
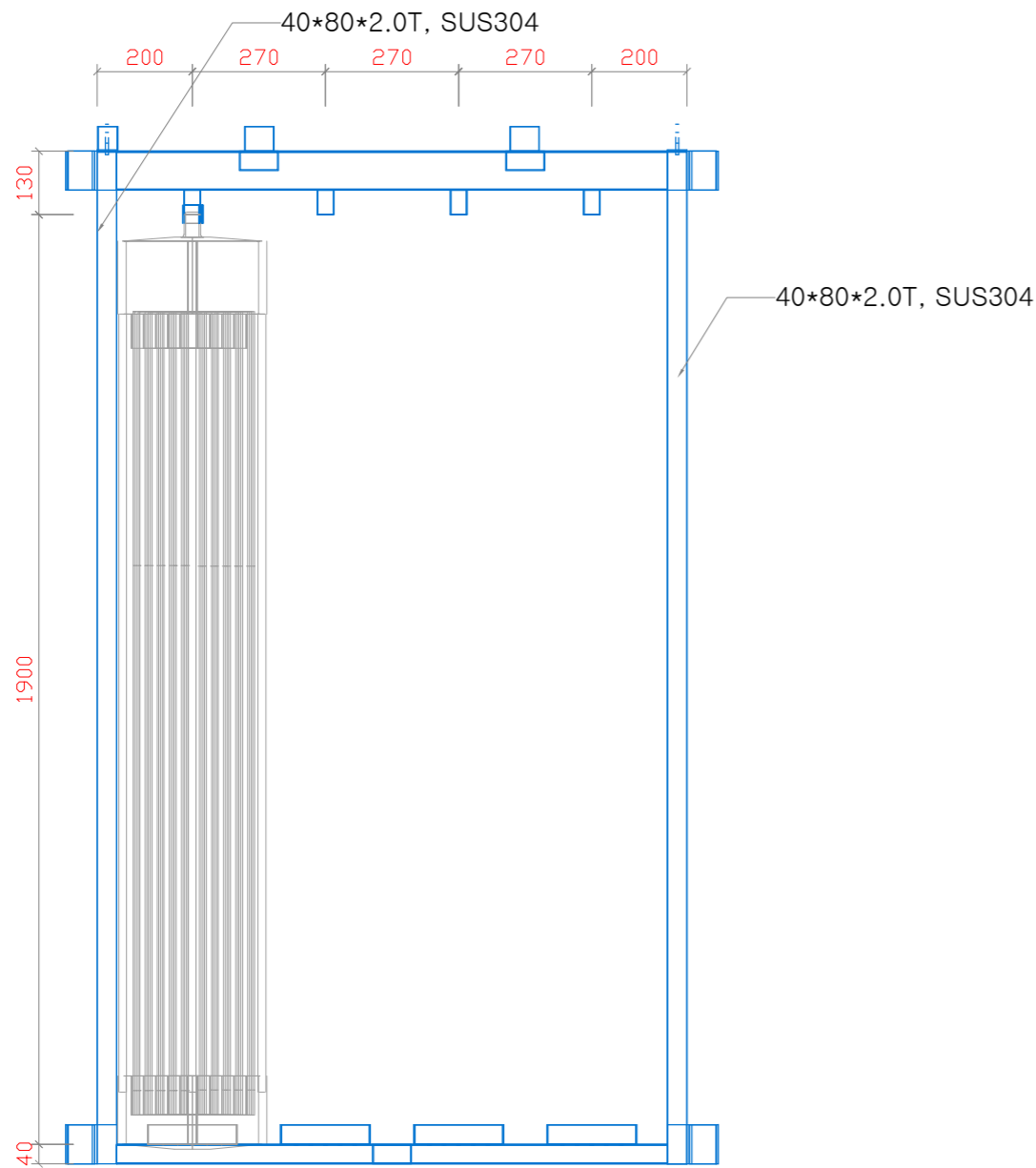
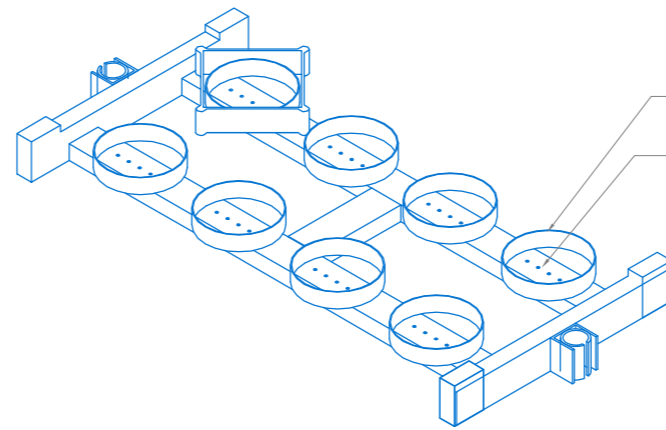
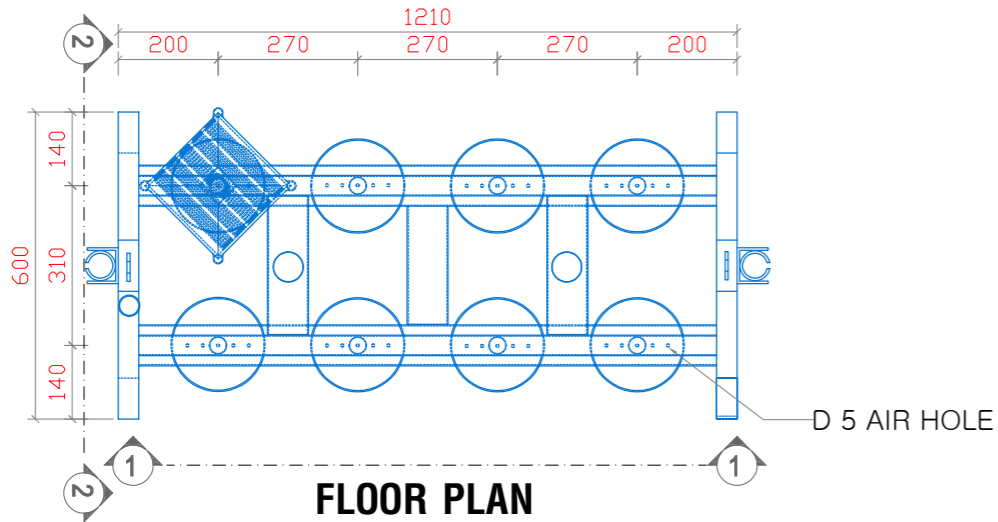

REV.	DATE	DESCRIPTION	DWN	CKD	RVD	PM

PROJECT NAME	
CLIENT	
DEERFOS MEMBRANES	
TITLE	DETAIL OF DFX-830 * 8F
SCALE	N/S
REV.	



DETAIL OF DFX-830*9F

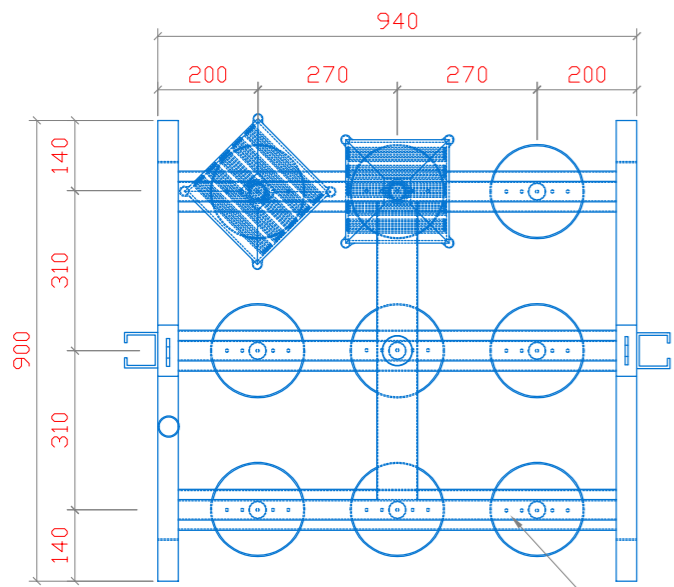

FLOOR PLAN

D 5 AIR HOLE

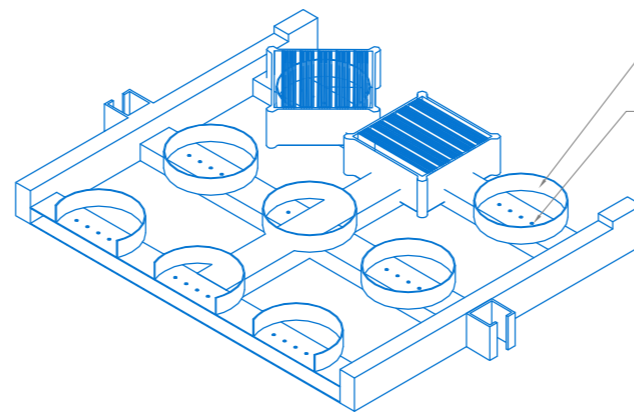

AIR HOLE DETAIL

UNDER SUPPORT D 184x40H, 3T

AIR HOLE D5

AIR LINE D42

40*80*2.0T, SUS304

WATER LINE D60

LIFTING LUG

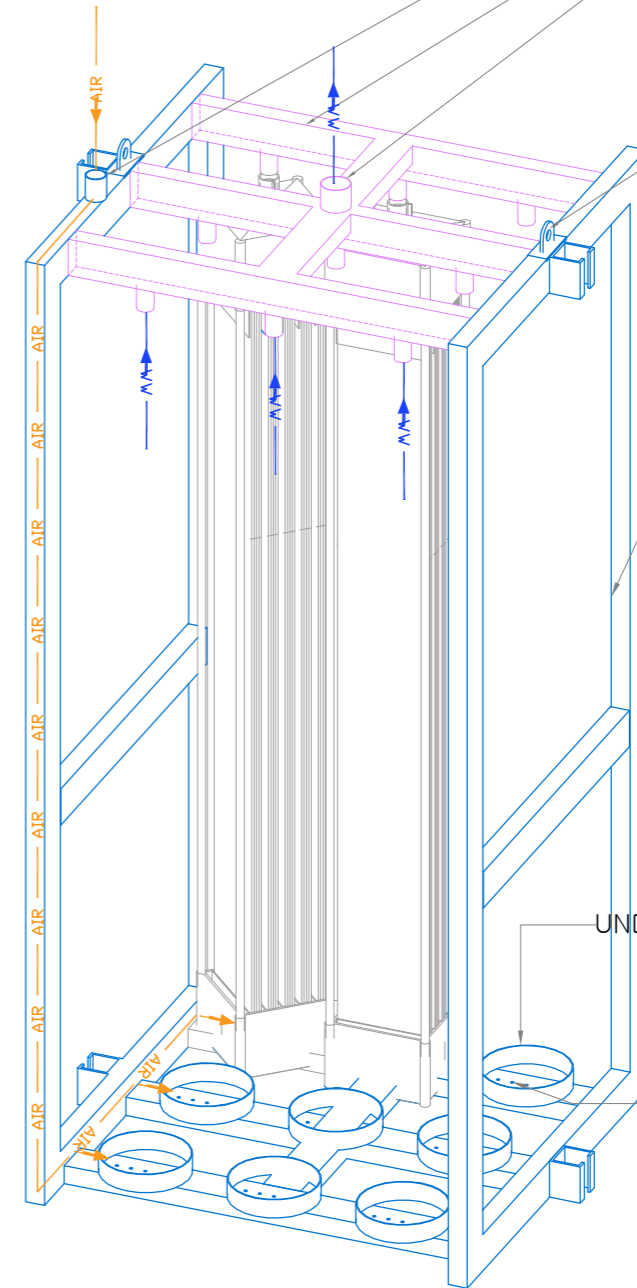

ISOMETRIC

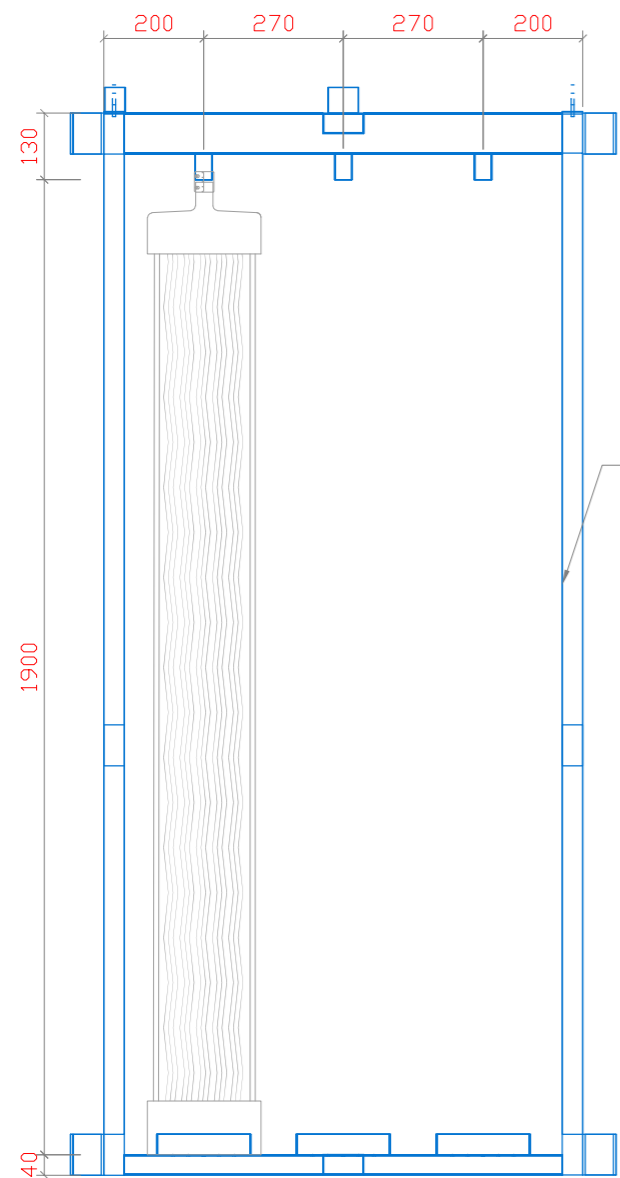

SECTION 1-1

40*80*2.0T, SUS304

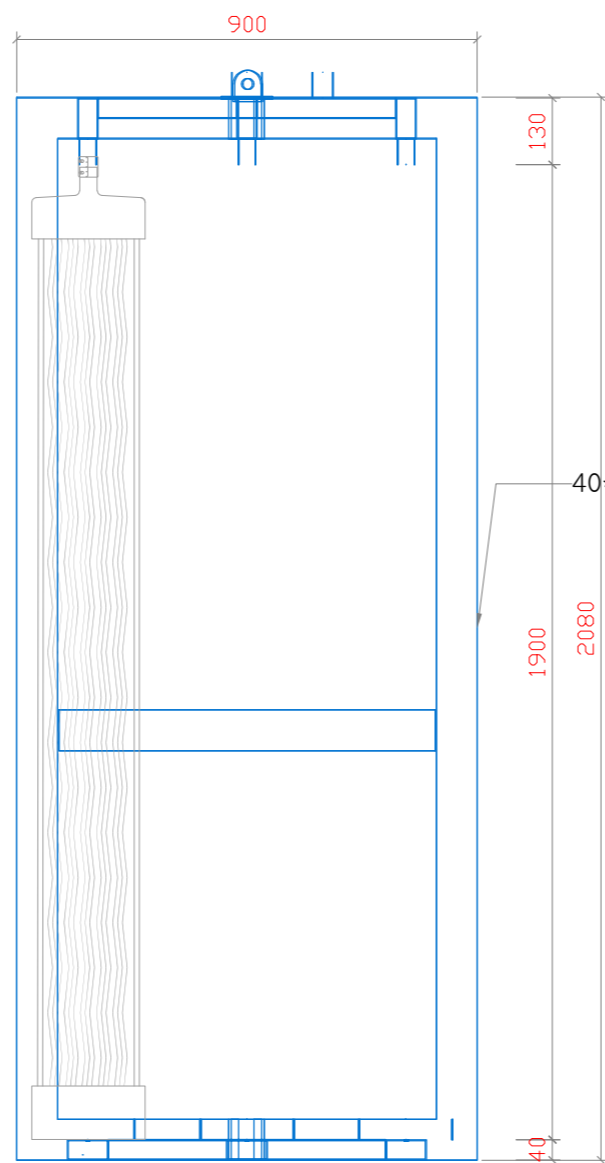

SECTION 2-2

40*80*2.0T, SUS304

PROJECT NAME					
CLIENT					
DEERFOS MEMBRANES					
TITLE	DETAIL OF DFX-830 * 9F				
SCALE	N/S				
REV. DATE	DESCRIPTION	DWN	CKD	RVD	PM

DETAIL OF DFX-830 * 9F

SCALE N/S

REV. DATE



DETAIL OF DFX-830*10F

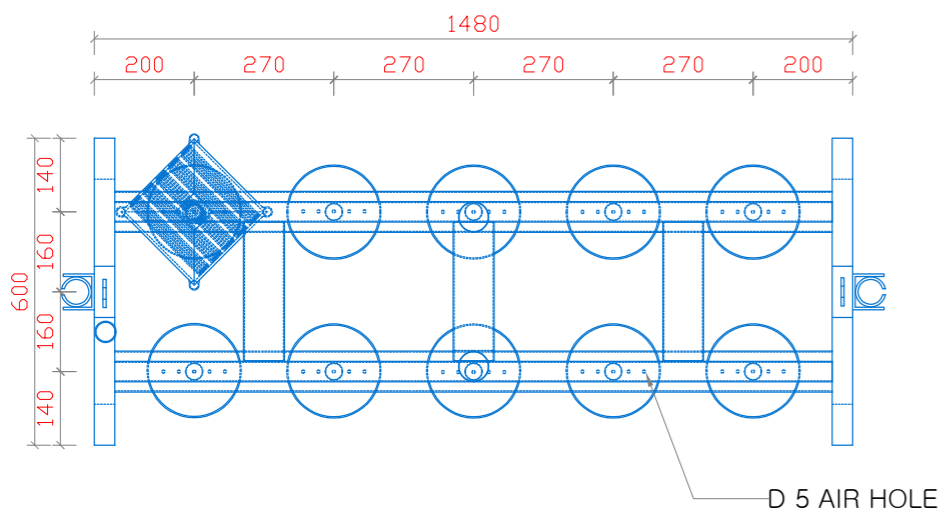

FLOOR PLAN

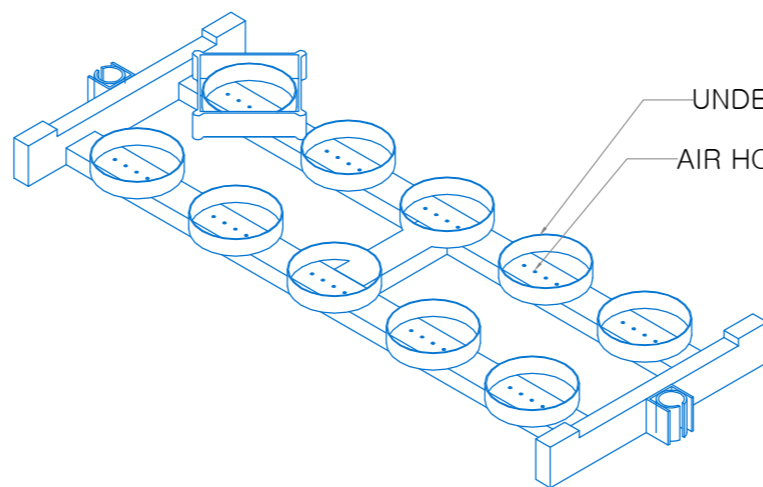

AIR HOLE DETAIL

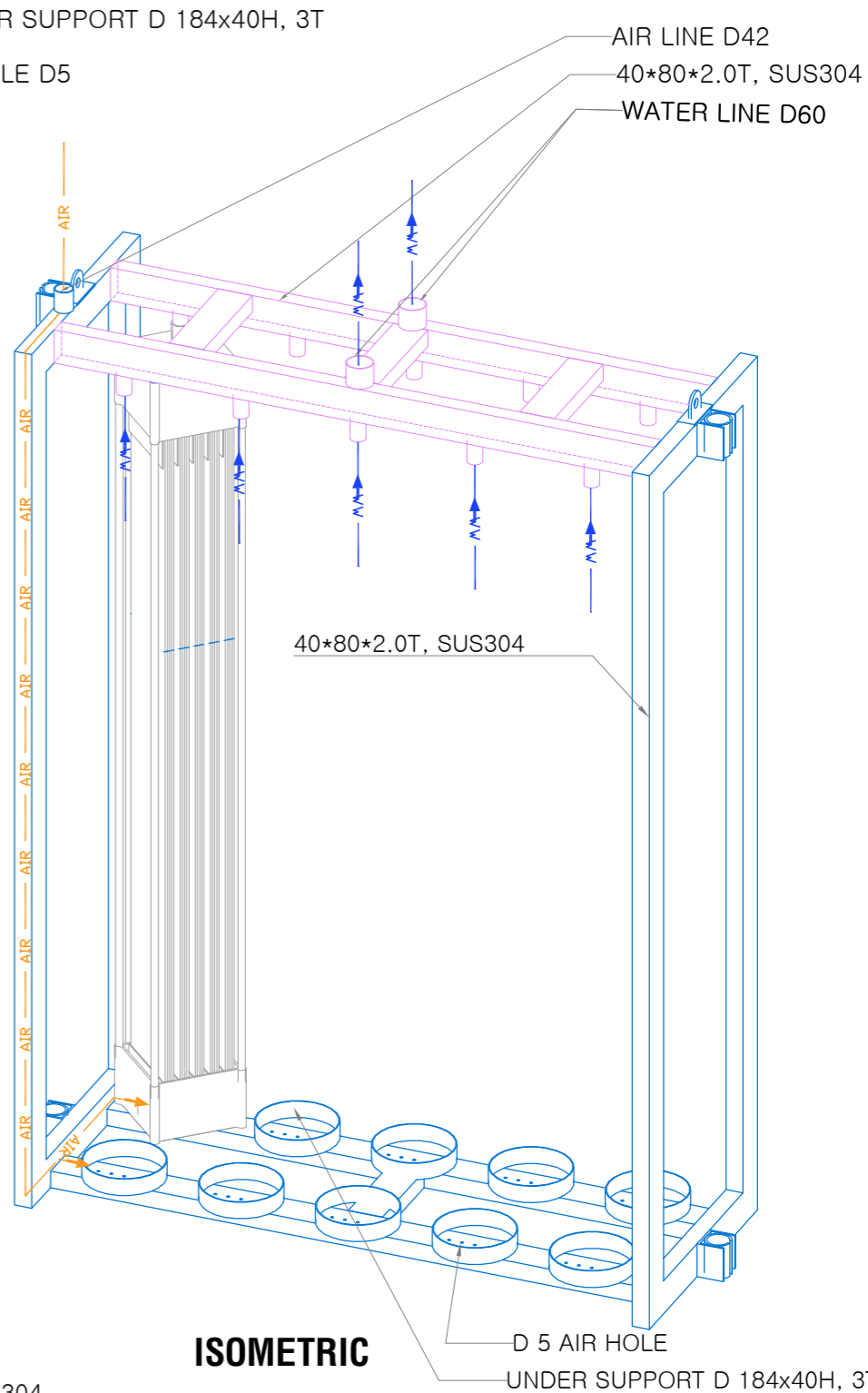

ISOMETRIC

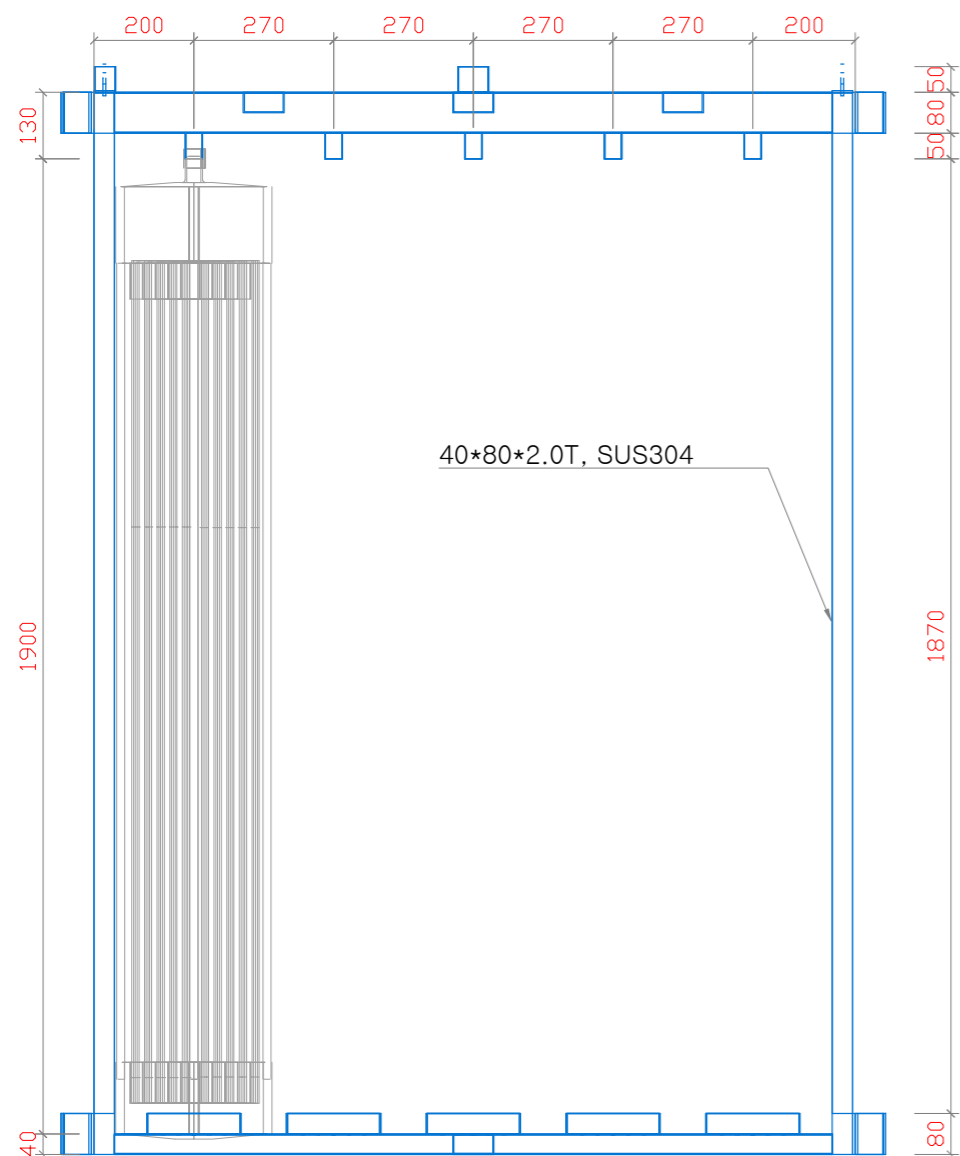

SECTION 1-1

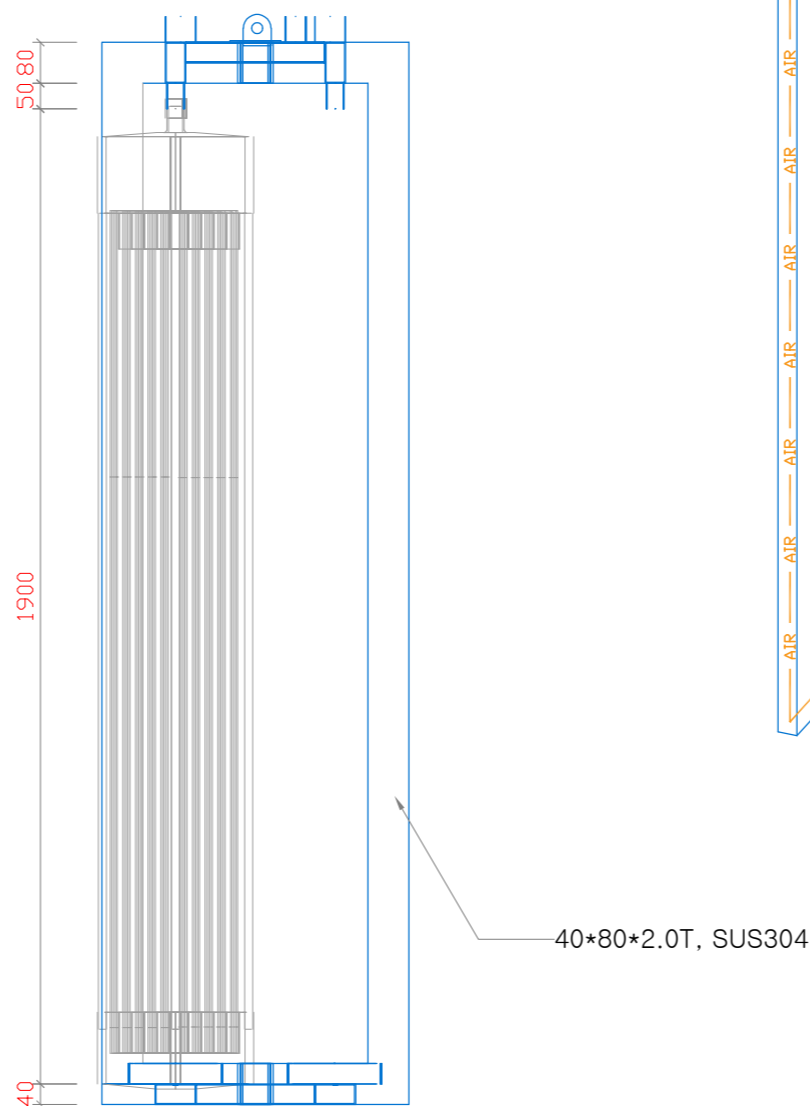

SECTION 2-2

REV.	DATE	DESCRIPTION	DWN	CKD	RVD	PM

PROJECT NAME		
CLIENT		
DEERFOS MEMBRANES		A
		ISSUE
DETAIL OF DFX-830 * 10F		A
		ISSUE
TITLE		DWG. START DATE
SCALE		REV.
N/S		



DETAIL OF DFX-830*12F

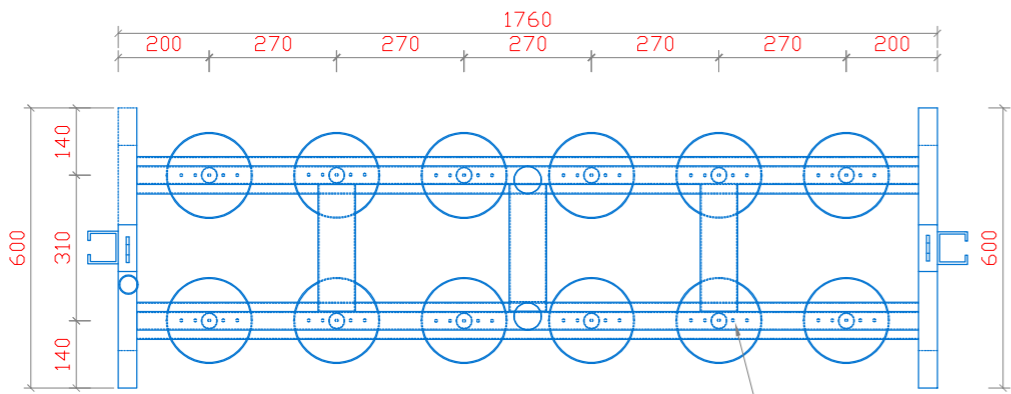

FLOOR PLAN

D 5 AIR HOLE

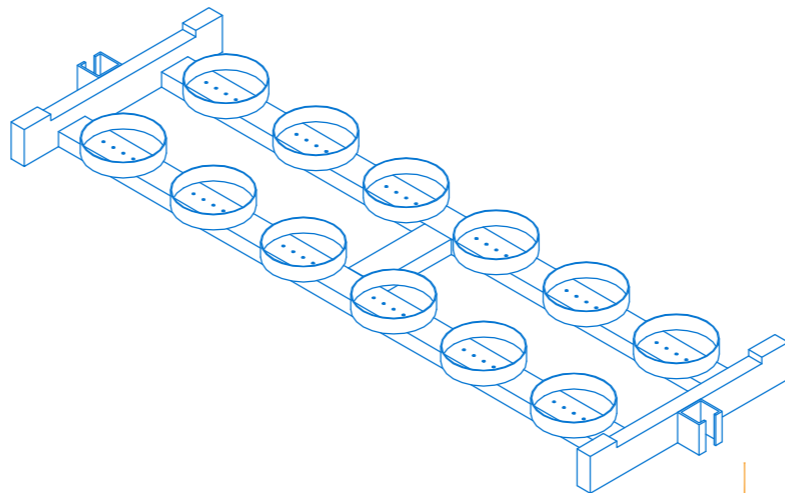

AIR HOLE DETAIL

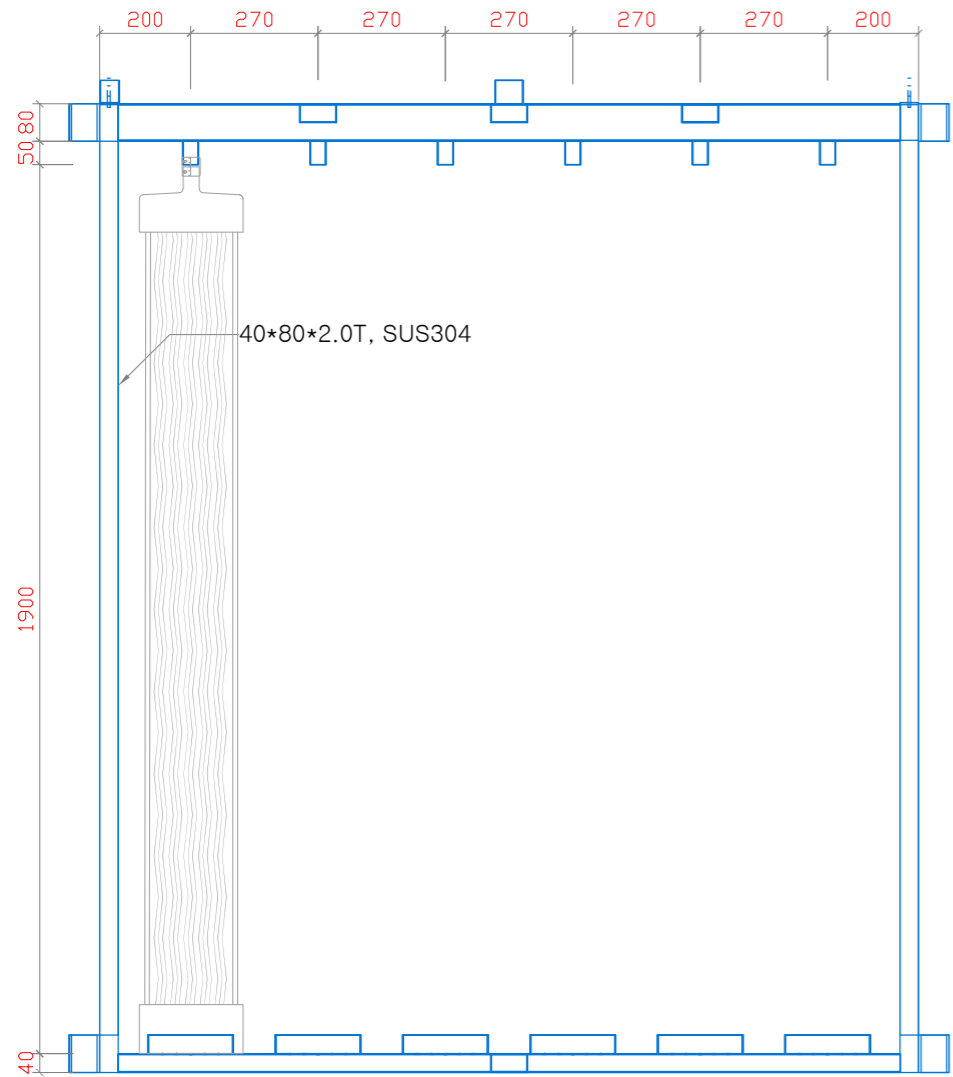

SECTION 1-1

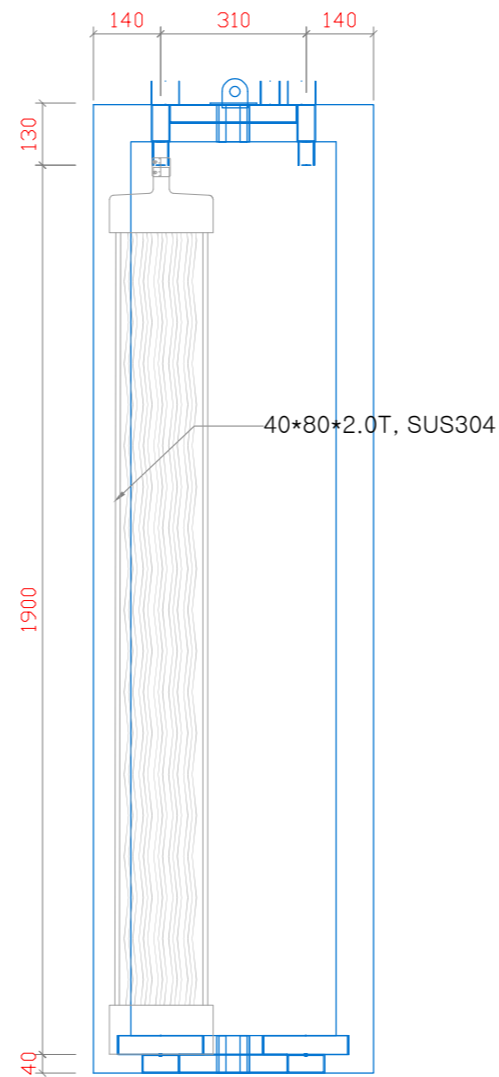

SECTION 2-2

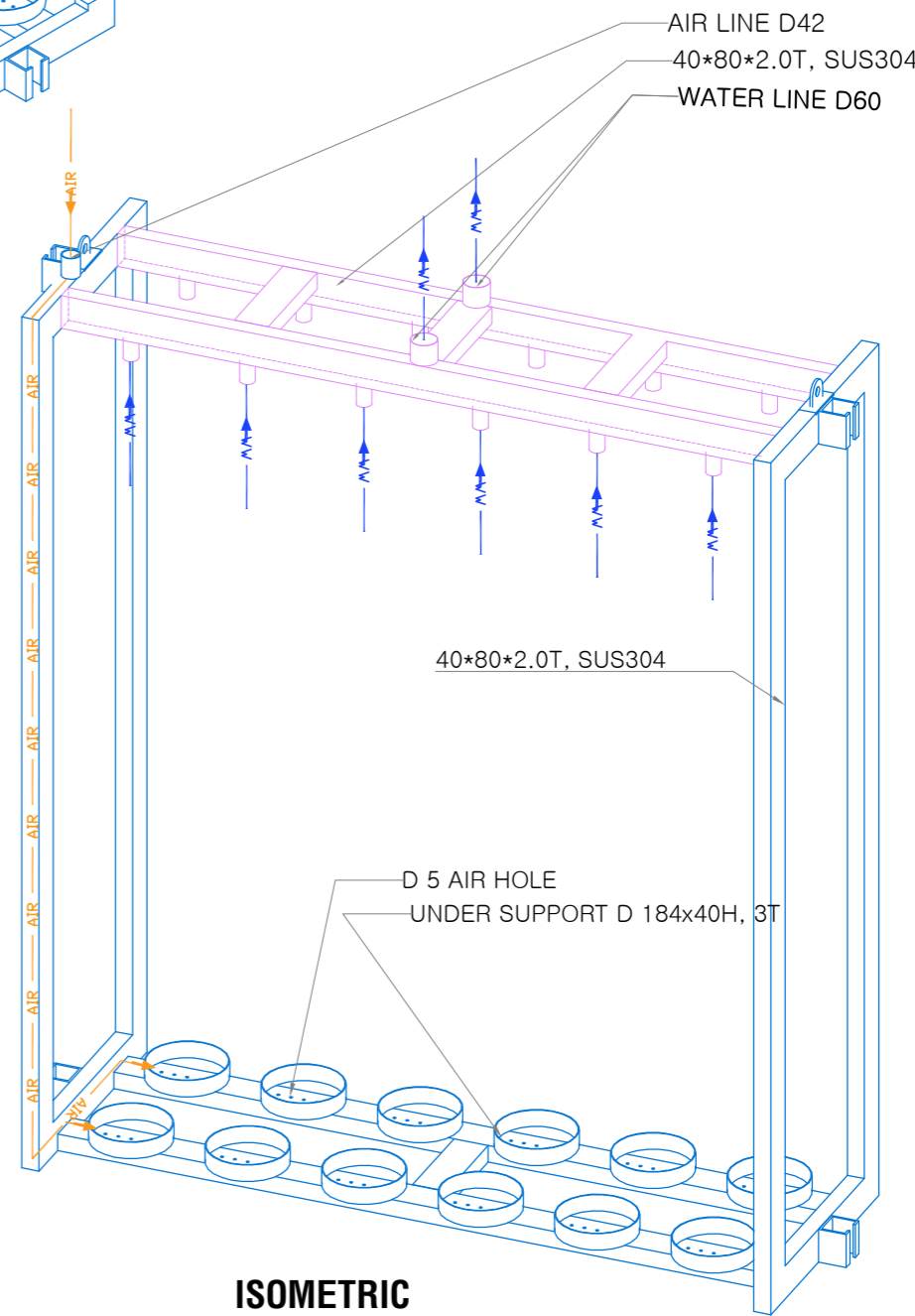

ISOMETRIC

PROJECT NAME		
CLIENT		A ISSUE
DEERFOS MEMBRANES		A ISSUE
TITLE	DETAIL OF DFX-830 * 12F	
SCALE		DWG. START DATE
		REV.
REV.	DATE	DESCRIPTION
		DWN CKD RVD PM

